

Dry Cast transformers

→ Standard line with Copper conductors

Tappings	± 2 x 2,5
Secondary voltage	400 - 231 V
Frequency	50 Hz
Vector group	Dyn11
Cooling system	AN
Thermal class	F
Protection degree	IP 00 (up to IP55)
Installation altitude (f.s.l.)	up to 1000 m

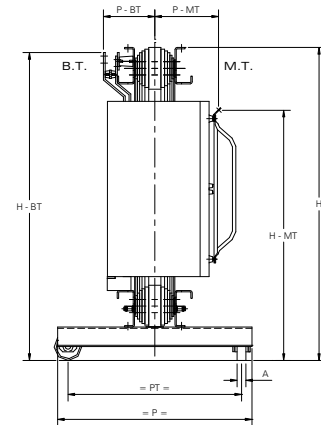
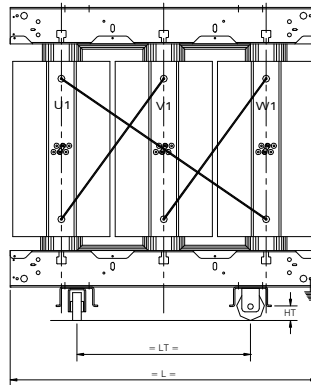

Class 17,5 kV

P	Po	Pcc	Ucc	Io	Sound	L	H	P	T	D	A	Weight
KVA	W		%		dB	mm						Kg
100	520	1800	6	2,1	58	1200	1100	680	600	100	40	952
125	570	2000	6	2	58	1220	1120	680	600	100	40	1040
160	640	2400	6	1,9	58	1240	1150	680	600	100	40	1080
200	720	2800	6	1,8	58	1270	1170	680	600	100	40	1170
250	830	3300	6	1,7	60	1300	1210	680	600	100	40	1310
315	960	3900	6	1,6	60	1340	1240	680	600	100	40	1430
400	1120	4700	6	1,5	60	1380	1300	900	800	130	45	1600
500	1300	5600	6	1,4	60	1440	1370	900	800	130	45	1880
630	1550	6800	6	1,3	62	1500	1440	900	800	130	45	2140
800	1850	8200	6	1,2	64	1580	1540	900	800	130	45	2550
1000	2200	9800	6	1,1	64	1650	1640	900	800	130	45	2930
1250	2600	11700	6	1	65	1730	1750	1120	1000	160	50	3510
1600	3150	14200	6	0,9	66	1850	1890	1120	1000	160	50	4330
2000	3700	16700	6	0,8	66	1920	2020	1120	1000	160	50	5150
2500	4300	19600	6	0,7	68	1970	2150	1120	1000	160	50	6320
3150	4900	22300	7	0,6	70	1980	2250	1120	1000	160	50	7730

Class 36 kV

P	Po	Pcc	Ucc	Io	Sound	L	H	P	T	D	A	Weight
KVA	W		%		dB	mm						Kg
100	630	2400	6	2,2	58	1400	1390	680	600	100	40	1210
125	680	2600	6	2,1	58	1420	1400	680	600	100	40	1290
160	820	2900	6	2	58	1440	1440	680	600	100	40	1380
200	930	3200	6	1,9	58	1460	1470	680	600	100	40	1500
250	1100	3600	6	1,8	58	1490	1500	680	600	100	40	1680
315	1250	4200	6	1,7	60	1520	1550	680	600	100	40	1870
400	1500	4800	6	1,6	60	1570	1600	900	800	130	45	2170
500	1800	5500	6	1,5	60	1630	1670	900	800	130	45	2460
630	2200	6600	6	1,4	62	1690	1750	900	800	130	45	2890
800	2600	7800	6	1,3	64	1770	1850	900	800	130	45	3400
1000	3100	9200	6	1,2	64	1860	1960	900	800	130	45	3980
1250	3700	11000	6	1,1	65	1950	2070	1120	1000	160	50	4680
1600	4400	13400	6	1	66	2060	2200	1120	1000	160	50	5620
2000	5000	15700	6	0,9	66	2160	2310	1120	1000	160	50	6550
2500	5500	18600	6	0,8	68	2240	2390	1120	1000	160	50	7600
3150	5900	22000	7	0,7	70	2260	2410	1120	1000	160	50	8660

Dry Type Cast transformers